

JOURNAL

de Théorie des Nombres
de BORDEAUX

anciennement Séminaire de Théorie des Nombres de Bordeaux

Andreas M. SCHÖPP

Fundamental units in a parametric family of not totally real quintic number fields

Tome 18, n° 3 (2006), p. 693-706.

<http://jtnb.cedram.org/item?id=JTNB_2006__18_3_693_0>

© Université Bordeaux 1, 2006, tous droits réservés.

L'accès aux articles de la revue « Journal de Théorie des Nombres de Bordeaux » (<http://jtnb.cedram.org/>), implique l'accord avec les conditions générales d'utilisation (<http://jtnb.cedram.org/legal/>). Toute reproduction en tout ou partie cet article sous quelque forme que ce soit pour tout usage autre que l'utilisation à fin strictement personnelle du copiste est constitutive d'une infraction pénale. Toute copie ou impression de ce fichier doit contenir la présente mention de copyright.

cedram

Article mis en ligne dans le cadre du
Centre de diffusion des revues académiques de mathématiques
<http://www.cedram.org/>

Fundamental units in a parametric family of not totally real quintic number fields

par ANDREAS M. SCHÖPP

Dedicated to Michael E. Pohst on the occasion of his 60th birthday.

RÉSUMÉ. Dans cet article, nous donnons des unités fondamentales pour une famille de corps de nombres engendrés par un polynôme paramétré de degré 5 avec signature $(1, 2)$ et groupe de Galois D_5 .

ABSTRACT. In this article we compute fundamental units for a family of number fields generated by a parametric polynomial of degree 5 with signature $(1, 2)$ and Galois group D_5 .

1. Introduction

Let K be a number field generated by a zero ρ of a monic irreducible polynomial $f \in \mathbb{Z}[x]$. Let n_K be the degree of K and r_K the unit rank of K . The computation of the unit group of an order of K can be done by several methods like the Voronoi algorithm (for $r_K \leq 2$), successive minima and other geometric methods using parallelotopes and ellipsoids. If f defines a parametric family of polynomials it is a problem to give the fundamental units of K in a parametric form, in particular for increasing degree n_K and rank r_K . For degrees $n_K \leq 3$ there are parametric systems of fundamental units known for several families of number fields of different unit rank (see for example [2] for unit rank 1 and degree $n_K = 2$ and $n_K = 3$, and [19], [23], [8] for $r_K = 2$ with $n_K = 3$).

In the case $n_K = 4$ Stender ([21], [22]) has obtained families with unit rank 2. Some families with unit rank 3 are described in the biquadratic case ([20], [3], [6], [25]) and in the non-biquadratic case ([13]). For $n_K = 5$ only a few families of number fields with explicit systems of fundamental units are known (see [12] for 2 families of degree 5 and rank 2 and 3, and see [17]). The parametric unit computation has been extended up to number fields of degree 8 with cyclic Galois group by Shen ([18]) or with Galois group isomorphic to $C_2 \times C_2 \times C_2$ by Wang ([24]).

In [9] we have constructed parametric polynomials $f_n(x)$ of degree n with Galois group either the dihedral group D_n of order $2n$, or the cyclic group C_n of order n using elliptic curves with rational points of order n . For $n = 4$ we computed in [10] parametric units which form a system of fundamental units under some conditions. The constructed polynomial $f_5(x)$ is isomorphic to the one of Brumer (for details see [9]). Kihel showed in [7] that any set of four roots of this polynomial forms (under certain conditions) a fundamental system of units of the splitting field.

In this article we compute parametric units in the case $n_K = 5$. We use a geometric observation and a Theorem of Obreschkoff. The computed units are fundamental for signature $(1, 2)$ under some conditions. This is proven by approximations of the complex roots of the generating polynomials.

2. The Polynomial $P_n(x)$

For $n \in \mathbb{Z}$ we consider the polynomials

$$P_{n,b,5}(x) = x^5 - n x^4 + b(2n + b^2 - b - 1)x^3 - b^2(n + b - 3)x^2 + b^3(b - 3)x + b^4$$

introduced in [9] and [16]. We only consider the case $b = \pm 1$. Since $P_{n,-1,5}(x) = P_{n+5,1,5}(x+1)$, we consider only the case $b = 1$, and set $P_n(x) = P_{n,1,5}(x) = x^5 - n x^4 + (2n - 1)x^3 - (n - 2)x^2 - 2x + 1$. These polynomials have discriminant $16(4n^3 - 28n^2 + 24n - 47)^2$, and are irreducible for every choice of $n \in \mathbb{Z}$ which is shown by a short computation modulo 2.

Lemma 2.1. *The polynomials $P_n(x)$ (with $b = 1$) have signature $(1, 2)$ for $n \leq 6$ and signature $(5, 0)$ for $n \geq 7$.*

Proof. The discriminant is positive for every $n \in \mathbb{Z}$ which implies that $P_n(x)$ have exactly one or five real roots. We have $P_n(-1) = -4n + 5 < 0$ for $n \geq 2$ and $P_n(0) = P_n(1) = 1 > 0$. Moreover $P_n(\frac{1}{2}) = \frac{-2n+13}{32} < 0$ for $n \geq 7$, hence there are at least three real roots for $n \geq 7$.

In the case $n < 7$ we compute the signature $(2, 1)$ with the help of a theorem of Sturm (in algorithmic version for example in H. Cohen [1], 4.1.10+4.1.11): Let l_0 be the leading coefficient of $A_0 = P_n$ (thus $l_0 = 1$), l_1 the leading coefficient of the derivation $A_1 = P'_n$ (thus $l_1 = 5$). For a polynomial division of $A_{i-2}(x)$ by $A_{i-1}(x)$ in the form $A_{i-2}(x) = A_{i-1}(x)Q_i(x) - A_i(x)$, let $l_i(n)$ be the leading coefficient of the rests $A_i(x)$ for $2 \leq i \leq 5$. Then a computation yields (apart from positive constant factors and quadratic denominators)

$$l_2(n) = 2n^2 - 10n + 5, \quad l_3(n) = n^4 - 4n^3 - 14n^2 + 6n - 22,$$

$$l_4(n) = (2n^2 + 6n + 3)(4n^3 - 28n^2 + 24n - 47)(2n^2 - 10n + 5)^2$$

and

$$l_5(n) = (n^4 - 4n^3 - 14n^2 + 6n - 22)^2.$$

Let $\omega(n)$ be the number of sign changes in the following sequence which depends on $n - l_0, l_1, -l_2(n), l_3(n), -l_4(n), l_5(n)$. And let $\nu(n)$ be the number of sign changes in $l_0, l_1, l_2(n), l_3(n), l_4(n), l_5(n)$. Then gives $\omega(n) - \nu(n)$ the number of real roots of $P_n(x)$. For every $n < 7$ we get $\omega(n) = 3$ and $\nu(n) = 2$ (even if the specific sequences differ). \square

3. The Galois group of $P_n(x)$

The Galois group of $P_n(x)$ over $\mathbb{Q}(n, b)$ is the dihedral group with 10 elements as shown in [9], Théorème 2.

Lemma 3.1. *For $b = 1$ the polynomials $P_n(x)$ have only for $n \in \{7, 18\}$ the Galois group C_5 ; both polynomials generate the same number field.*

Proof. Geißler gives in [4] a condition for polynomials to have cyclic Galois group: the expression $\sum_{i=1}^5 x_i x_{i+1}^2$ have to be rational for the roots x_i of $P_n(x)$. This is equivalent to the existence of rational points on certain elliptic curves (quotient curves) as shown in [9]. For $P_n(x)$ this quotient elliptic curve is

$$z^2 = 4n^3 + (b^2 - 30b + 1)n^2 - 2b(3b + 1)(4b - 7)n - b(4b^4 - 4b^3 - 40b^2 + 91b - 4)$$

and with $b = 1$ we have $z^2 = 4n^3 - 28n^2 + 24n - 47$. With the computer algebra system MAGMA [11] we compute the Mordell-Weil group over \mathbb{Q} to $\mathbb{Z}/5\mathbb{Z}$ where all finite points have n -coordinate 7 or 18. Therefore only the polynomials

$$P_7(x) = x^5 - 7x^4 + 13x^3 - 5x^2 - 2x + 1,$$

and

$$P_{18}(x) = x^5 - 18x^4 + 35x^3 - 16x^2 - 2x + 1$$

have the Galois group C_5 . With the computer algebra system KANT [5] it is easy to show that for a root ρ of $P_7(x)$ the algebraic number $2\rho^3 - 9\rho^2 + 2\rho + 1$ is a root of $P_{18}(x)$. \square

4. Parametric units

By Lemma 2.1 for $n \leq 6$ the number fields K generated by $P_n(x)$ have two fundamental units. Since $P_n(x) = x(x-1)(x^3 - (n-1)x^2 + nx + 2) + 1$, ρ and $\rho - 1$ are units in K .¹

Theorem 4.1. *The elements $\rho, \rho - 1$ build a system of independent units in the equation order $\mathbb{Z}[\rho]$. Moreover they are fundamental in $\mathbb{Z}[\rho]$ for $n < 6$.*

¹In the cases $n \geq 7$ we were not able to find more parametric units.

Remark. In the case $n = 6$ the units ρ and $\rho - 1$ are independent which is proved by KANT [5]. They don't generate the full unit group of $\mathbb{Z}[\rho]$. The set $\{2\rho^4 - 11\rho^3 + 16\rho^2 + 2\rho - 4, \rho^4 - 5\rho^3 + 6\rho^2 + 3\rho - 2\}$ is a system of fundamental units. The equation order is maximal in this case.

The proof of this theorem needs an approximation of the absolute values of the considered elements ρ and $\rho - 1$ and of their conjugates. Since ρ is a root of $P_n(x)$ its conjugates are the other roots.

Lemma 4.2. *Let $n \geq 7$. Let $\rho^{(1)}, \rho^{(2)}, \rho^{(3)}, \rho^{(4)}$ and $\rho^{(5)}$ be the real roots of $P_n(x)$. Then we have the following approximations:*

$$\begin{aligned}
 & -1 < -\frac{1}{\sqrt{n}} - \frac{1}{n} < \rho^{(1)} < -\frac{1}{\sqrt{n}} < 0 < \frac{1}{\sqrt{n}} < \rho^{(2)} < \frac{1}{\sqrt{n}} + \frac{1}{n} < \frac{3}{5}, \\
 & \frac{3}{5} < 1 - \frac{1}{\sqrt{n}} < \rho^{(3)} < 1 - \frac{1}{\sqrt{n}} + \frac{1}{n} < 1 < 1 + \frac{1}{\sqrt{n}} + \frac{1}{n} < \rho^{(4)} < 1 + \frac{1}{\sqrt{n}} + \frac{5}{n} < 3 \\
 & \text{and} \\
 & 3 < n - 3 < \rho^{(5)} < n - 2.
 \end{aligned}$$

Proof. This is easy to see because of the sign changes of $P_n(x)$. For $n \geq 7$ we have the inequalities:

$$\begin{aligned}
 P_n\left(-\frac{1}{\sqrt{n}} - \frac{1}{n}\right) &= \frac{-2n^{4,5} - 4n^4 - 5n^{3,5} - 3n^3 - 2n^{2,5} - 5n^2 - 10n^{1,5} - 10n - 5\sqrt{n} - 1}{n^5} < 0, \\
 P_n\left(-\frac{1}{\sqrt{n}}\right) &= \frac{n^{1,5} + n - 1}{n^{2,5}} > 0, \\
 P_n\left(\frac{1}{\sqrt{n}}\right) &= \frac{n^{1,5} - n + 1}{n^{2,5}} > 0, \\
 P_n\left(\frac{1}{\sqrt{n}} + \frac{1}{n}\right) &= \frac{-2n^{4,5} + 4n^4 + 5n^{3,5} - 5n^3 - 6n^{2,5} + 3n^2 + 10n^{1,5} + 10n + 5\sqrt{n} + 1}{n^5} < 0, \\
 P_n\left(1 - \frac{1}{\sqrt{n}}\right) &= \frac{-2n^2 + 8n^{1,5} - 9n + 5\sqrt{n} - 1}{n^{2,5}} < 0, \\
 P_n\left(1 - \frac{1}{\sqrt{n}} + \frac{1}{n}\right) &= \frac{5n^4 - 17n^{3,5} + 33n^3 - 44n^{2,5} + 43n^2 - 30n^{1,5} + 15n - 5\sqrt{n} + 1}{n^5} > 0, \\
 P_n\left(1 + \frac{1}{\sqrt{n}} + \frac{1}{n}\right) &= \frac{5n^4 + 17n^{3,5} + 33n^3 + 44n^{2,5} + 43n^2 + 30n^{1,5} + 15n + 5\sqrt{n} + 1}{n^5} > 0, \\
 P_n\left(1 + \frac{1}{\sqrt{n}} + \frac{5}{n}\right) &= \\
 & \frac{-8n^{4,5} - 27n^4 - 71n^{3,5} - 35n^3 + 276n^{2,5} + 1275n^2 + 2750n^{1,5} + 4375n + 3125\sqrt{n} + 3125}{n^5} < 0, \\
 P_n(n - 3) &= -n^4 + 16n^3 - 91n^2 + 220n - 191 < 0, \\
 P_n(n - 2) &= 2n^3 - 12n^2 + 22n - 11 > 0.
 \end{aligned}$$

□

For $n \leq 6$ we have to find approximations of the absolute values of the complex roots. For this we use the following theorem of Obreschkoff [14]:

Lemma 4.3 ([14], page 9). *Let $f(x)$ be a polynomial of degree m and α an arbitrary complex number with $f(\alpha) \neq 0$ and $f'(\alpha) \neq 0$. Then there is inside and outside of every circle C through α and $\alpha - \frac{mf(\alpha)}{f'(\alpha)}$ at least one root of $f(x) = 0$, if not all roots are lying exactly on C .*

With this Lemma we show the following result.

Lemma 4.4. *Let $\rho^{(1)}$ be the real root and let $\rho^{(2)} = \overline{\rho^{(3)}}$, $\rho^{(4)} = \overline{\rho^{(5)}}$ be the pairs of complex roots of $P_n(x)$ (with $b = 1$). Then we have the following approximations:*

- (i) $-n + 2 + \frac{2}{n} < |\rho^{(1)}| < -n + 2 + \frac{1}{n}$ for $n < -4$
- (ii) $-n + 3 + \frac{2}{n} < |\rho^{(1)} - 1| < -n + 3 + \frac{1}{n}$ for $n < -4$
- (iii) $\frac{1}{2\sqrt{-n}} < |\rho^{(2)}| < \frac{2}{\sqrt{-n}}$ for $n < -4$
- (iv) $\sqrt{1 - \frac{3}{4n}} < |\rho^{(2)} - 1| < \sqrt{1 - \frac{6}{5n}}$ for $n < -144$
- (v) $\sqrt{1 + \frac{3}{n}} < |\rho^{(4)}| < \sqrt{1 - \frac{1}{n^2}}$ for $n < -174$
- (vi) $\sqrt{-\frac{5}{6n}} < |\rho^{(4)} - 1| < \sqrt{-\frac{14}{13n}}$ for $n < -139$

Proof. The following considerations are for $n < -4$. Since n is negative it will be easier to substitute n by $-n$. Thus we study the polynomial resulting from $P_n(x)$

$$f(x) = x^5 + nx^4 - (2n + 1)x^3 + (n + 2)x^2 - 2x + 1$$

and its roots $\varrho^{(1)}, \dots, \varrho^{(5)}$.

Again, the real root is found by looking for a sign change. The determination of the position of the complex roots is laborious: With Lemma 4.3 we construct a circle around one root of a pair of complex roots. Around the circle we put a square whose corners will give an approximation of the absolute value of the root.

(i)+(ii) *Real root $\rho^{(1)}$ of $P_n(x)$:*

For the real root $\varrho^{(1)}$ of $f(x)$ we have

$$-n - 2 + \frac{1}{n} < \varrho^{(1)} < -n - 2 + \frac{2}{n},$$

because of the inequalities

$$f\left(-n - 2 + \frac{1}{n}\right) = \frac{-n^8 - 2n^7 + 17n^6 + 43n^5 - 16n^4 - 42n^3 + 35n^2 - 10n + 1}{n^5} < 0$$

and

$$f\left(-n - 2 + \frac{2}{n}\right) = \frac{8n^7 + 48n^6 + 37n^5 - 156n^4 - 48n^3 + 248n^2 - 160n + 32}{n^5} > 0$$

for $n > 4$. The Approximation for $|\rho^{(1)}|$ and for $|\rho^{(1)} - 1|$ follows.

(iii) First pair of complex roots $\rho^{(2)} = \overline{\rho^{(3)}}$ of $P_n(x)$:

For an approximation of the roots $\rho^{(2)} = \overline{\rho^{(3)}}$ of $f(x)$ with Lemma 4.3 we choose $\alpha = \frac{1}{2n^2} + \frac{i}{\sqrt{n}}$ for $n > 4$. For these n we have $0 < \Re(\alpha), \Im(\alpha) < 1$.

It is $f(\alpha) \neq 0$ and $f'(\alpha) \neq 0$. The real part of $\frac{5f(\alpha)}{f'(\alpha)}$ is

$$\frac{5(96n^{16} - 16n^{15} + 48n^{14} - 240n^{13} + 78n^{12} + 27n^{11} - 16n^{10} + 78n^9 + \dots)}{4n^2(16n^{17} + 64n^{16} + 32n^{15} + 48n^{14} + 16n^{13} + 76n^{12} + 112n^{11} - 13n^{10} + 149n^9 + \dots)}$$

and the imaginary part is

$$\frac{5(16n^{16} + 32n^{15} + 20n^{14} + 48n^{13} - 8n^{12} + 104n^{11} - 29n^{10} + 38n^9 + \dots)}{2\sqrt{n}(16n^{17} + 64n^{16} + 32n^{15} + 48n^{14} + 16n^{13} + 76n^{12} + 112n^{11} - 13n^{10} + 149n^9 + \dots)}.$$

For all $n > 4$ we have $0 < \Im(\alpha - \frac{5f(\alpha)}{f'(\alpha)}) < 1$. For $4 < n \leq 10$ the complex number $\alpha - \frac{5f(\alpha)}{f'(\alpha)}$ lies in the second quadrant with $-1 < \Re(\alpha - \frac{5f(\alpha)}{f'(\alpha)}) < 0$.

For $n > 10$ we have $0 < \Re(\alpha - \frac{5f(\alpha)}{f'(\alpha)}) < 1$.

Let C be the circle through α and $\alpha - \frac{5f(\alpha)}{f'(\alpha)}$ with exact diameter $\frac{5f(\alpha)}{f'(\alpha)}$ for $n > 4$. The root $\rho^{(1)}$ lies not inside and not on the circle (since it lies close to $-n - 2$). Lemma 4.3 shows that there is (at least) one root $\rho^{(2)}$ of $f(x)$ inside the circle C . To find an approximation of the distance of $\rho^{(2)}$ to the origin we construct a square around C .

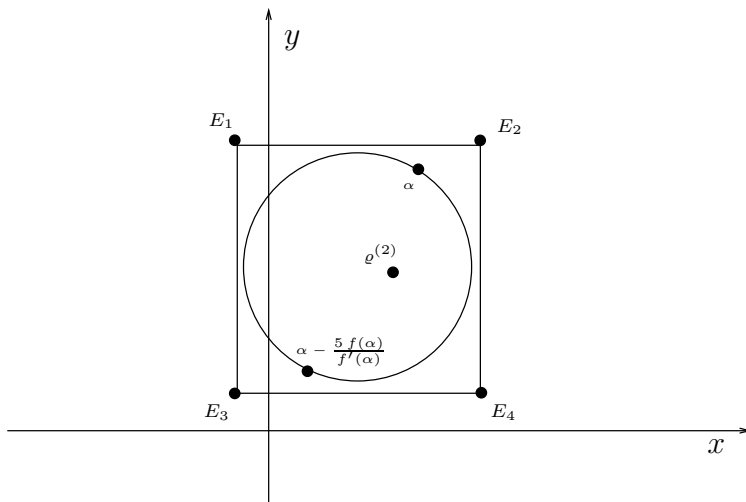

FIGURE 1. Approximation of $\rho^{(2)}$

The center of the circle is $\alpha - \frac{5f(\alpha)}{2f'(\alpha)}$. Starting there we construct the corners of the square. Since the inequality

$$\left| \frac{5f(\alpha)}{f'(\alpha)} \right|^2 = \frac{25(16n^{18} + 72n^{16} - 16n^{15} + 57n^{14} - 44n^{13} + 24n^{12} + 10n^{11} + \dots)}{4n^4(16n^{17} + 64n^{16} + 32n^{15} + 48n^{14} + 16n^{13} + 76n^{12} + 112n^{11} + \dots)} < \frac{25}{4n(n+1)^2}$$

holds for the square of the diameter of the circle for all $n > 2$, it follows that the radius of the circle is less than $\frac{5}{4\sqrt{n(n+1)}}$. With this we compute the corners of the square as

$$\alpha - \frac{5f(\alpha)}{2f'(\alpha)} \pm \frac{5}{4\sqrt{n(n+1)}} \pm \frac{5i}{4\sqrt{n(n+1)}}$$

and obtain

$$\begin{aligned} E_1 &= \frac{-5n^{19} + 2n^{18,5} - 20n^{18} - 5n^{17,5} - 10n^{17} + \dots}{4n^{2,5}(n+1)(n^{17} + 4n^{16} + 2n^{15} + 3n^{14} + \dots)} + \frac{4n^{18} + 20n^{17} + 29n^{16} + \dots}{4\sqrt{n}(n+1)(n^{17} + 4n^{16} + \dots)} i, \\ E_2 &= \frac{5n^{19} + 2n^{18,5} + 20n^{18} - 5n^{17,5} + 10n^{17} + \dots}{4n^{2,5}(n+1)(n^{17} + 4n^{16} + 2n^{15} + 3n^{14} + \dots)} + \frac{4n^{18} + 20n^{17} + 29n^{16} + \dots}{4\sqrt{n}(n+1)(n^{17} + 4n^{16} + \dots)} i, \\ E_3 &= \frac{-5n^{19} + 2n^{18,5} - 20n^{18} - 5n^{17,5} - 10n^{17} + \dots}{4n^{2,5}(n+1)(n^{17} + 4n^{16} + 2n^{15} + 3n^{14} + \dots)} + \frac{4n^{18} + 10n^{17} - 11n^{16} + \dots}{4\sqrt{n}(n+1)(n^{17} + 4n^{16} + \dots)} i, \\ E_4 &= \frac{5n^{19} + 2n^{18,5} + 20n^{18} - 5n^{17,5} + 10n^{17} + \dots}{4n^{2,5}(n+1)(n^{17} + 4n^{16} + 2n^{15} + 3n^{14} + \dots)} + \frac{4n^{18} + 10n^{17} - 11n^{16} + \dots}{4\sqrt{n}(n+1)(n^{17} + 4n^{16} + \dots)} i. \end{aligned}$$

We see that the corners E_1 and E_3 lie in the second quadrant for all $n > 4$. Moreover the signs of the coefficients show that the distance from E_1 to the origin is less than the distance of E_2 to the origin. Therefore we get the following approximation for $|\varrho^{(2)}|$:

$$|\Im(E_3)| < |\varrho^{(2)}| < |E_2|.$$

With the inequality

$$\Im(E_3) = \frac{4n^{18} + 10n^{17} - 11n^{16} + \dots}{4\sqrt{n}(n+1)(n^{17} + 4n^{16} + \dots)} > \frac{1}{2\sqrt{n}}$$

which holds for all $n > 4$ and with the approximation (for $n > 4$)

$$|E_2| = \left(\left(\frac{5n^{19} + 2n^{18,5} + \dots}{4n^{2,5}(n+1)(n^{17} + 4n^{16} + \dots)} \right)^2 + \left(\frac{4n^{18} + 20n^{17} + \dots}{4\sqrt{n}(n+1)(n^{17} + 4n^{16} + \dots)} \right)^2 \right)^{1/2} < \frac{2}{\sqrt{n}}$$

the assertion for $|\varrho^{(2)}|$ follows.

(iv) The translated number $\varrho^{(2)} - 1$:

Before approximating $|\varrho^{(2)} - 1|$ we remark that the translation by -1 changes only the real part which makes things a little bit more complicated than for real roots.

The corners of the square E_1, \dots, E_4 lie close² to the origin. Therefore the translation of $\varrho^{(2)}$ by -1 yields the situation shown in Figure 2.

²For all $n > 4$ the inequality $0 < \Re(E_i) < 1$ holds for $i = 2, 4$ and $-1 < \Re(E_j) < 0$ holds for $j = 1, 3$ and $0 < \Im(E_i) < 1$ holds for $i = 1, 2, 3, 4$.

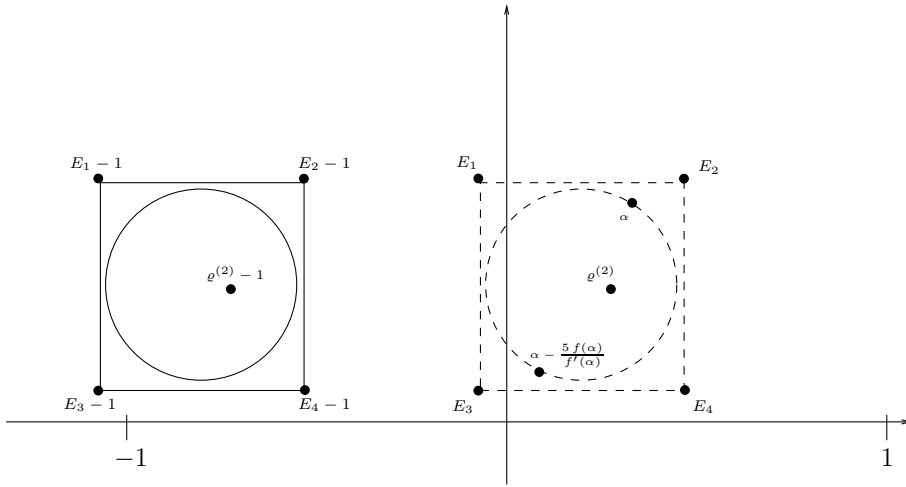

FIGURE 2. Approximation of $\rho^{(2)} - 1$

Now all new corners $E_1 - 1, \dots, E_4 - 1$ lie in the second quadrant and we get the approximation

$$|E_1 - 1| > |\rho^{(2)} - 1| > |E_4 - 1|.$$

The computation yields the inequalities

$$\begin{aligned} |E_1 - 1| &= \left(\left(\frac{-5n^{19} + 2n^{18.5} + \dots}{4n^{2.5}(n+1)(n^{17} + 4n^{16} + \dots)} - 1 \right)^2 + \left(\frac{4n^{18} + 20n^{17} + \dots}{4\sqrt{n}(n+1)(n^{17} + 4n^{16} + \dots)} \right)^2 \right)^{(1/2)} \\ &< \sqrt{1 + \frac{6}{5n}} \end{aligned}$$

for $n > 144$ and

$$\begin{aligned} |E_4 - 1| &= \left(\left(\frac{5n^{19} + 2n^{18.5} + \dots}{4n^{2.5}(n+1)(n^{17} + 4n^{16} + \dots)} - 1 \right)^2 + \left(\frac{4n^{18} + 10n^{17} + \dots}{4\sqrt{n}(n+1)(n^{17} + 4n^{16} + \dots)} \right)^2 \right)^{(1/2)} \\ &> \sqrt{1 + \frac{3}{4n}} \end{aligned}$$

for $n > 141$. The assertion for $\rho^{(2)} - 1$ follows.

(v) *Second pair of complex roots $\rho^{(4)} = \overline{\rho^{(5)}}$ of $P_n(x)$:*

The approximation of the roots $\rho^{(4)} = \overline{\rho^{(5)}}$ of $f(x)$ is analogue to the preceding approximation. In this case we chose $\alpha = 1 - \frac{1}{n} + \frac{3}{n^2} + \frac{i}{\sqrt{n}}$ and again we have $f(\alpha) \neq 0 \neq f'(\alpha)$. The real part of $\frac{5f(\alpha)}{f'(\alpha)}$ is

$$\frac{-5(2n^{17} - 99n^{16} + 269n^{15} - 1653n^{14} + 4000n^{13} - 14112n^{12} + 27794n^{11} - 68041n^{10} + \dots)}{n^2(4n^{17} + 24n^{16} + 68n^{15} + 457n^{14} - 496n^{13} + 6296n^{12} - 10300n^{11} + 36408n^{10} + \dots)}$$

and the imaginary part is

$$\frac{5(10n^{16} + 12n^{15} + 89n^{14} - 50n^{13} + 1092n^{12} - 1186n^{11} + 4850n^{10} - 5108n^9 + \dots)}{\sqrt{n(4n^{17} + 24n^{16} + 68n^{15} + 457n^{14} - 496n^{13} + 6296n^{12} - 10300n^{11} + 36408n^{10} - 53116n^9 + \dots)}}.$$

For $n > 4$ the real part of $\alpha - \frac{5f(\alpha)}{f'(\alpha)}$ is greater than zero and the imaginary part of this number is positive for $n > 6$: for $n > 6$ both α and $\alpha - \frac{5f(\alpha)}{f'(\alpha)}$ lie in the first quadrant. As before the real and the imaginary part are both smaller than 1.

Again we construct a circle C and an enclosing square with corners R_1, \dots, R_4 . We get the approximation of the diameter of the circle

$$\begin{aligned} \left| \frac{5f(\alpha)}{f'(\alpha)} \right|^2 &= \frac{25(25n^{18} - 89n^{17} + 491n^{16} - 1286n^{15} + 4809n^{14} - 11164n^{13} + 29414n^{12} + \dots)}{n^4(4n^{17} + 24n^{16} + 68n^{15} + 457n^{14} - 496n^{13} + 6296n^{12} - 10300n^{11} + \dots)} \\ &< \frac{625}{4n^3} \end{aligned}$$

for all $n > 0$. The computation of the corners R_1, \dots, R_4 of the square in the form

$$\alpha - \frac{5f(\alpha)}{2f'(\alpha)} \pm \frac{25}{4n\sqrt{n}} \pm \frac{25i}{4n\sqrt{n}}$$

yields:

$$\begin{aligned} R_1 &= \frac{4n^{20,5} + 20n^{19,5} - 25n^{19} + 61n^{18,5} + \dots}{4n^{20,5} + 24n^{19,5} + 68n^{18,5} + \dots} + \frac{8n^{18} + 48n^{17} + 376n^{16} + 1319n^{15} + \dots}{8n^{18,5} + 48n^{17,5} + 136n^{16,5} + 914n^{15,5} + \dots} i, \\ R_2 &= \frac{4n^{20,5} + 20n^{19,5} + 25n^{19} + 61n^{18,5} + \dots}{4n^{20,5} + 24n^{19,5} + 68n^{18,5} + \dots} + \frac{8n^{18} + 48n^{17} + 376n^{16} + 1319n^{15} + \dots}{8n^{18,5} + 48n^{17,5} + 136n^{16,5} + 914n^{15,5} + \dots} i, \\ R_3 &= \frac{4n^{20,5} + 20n^{19,5} - 25n^{19} + 61n^{18,5} + \dots}{4n^{20,5} + 24n^{19,5} + 68n^{18,5} + \dots} + \frac{8n^{18} - 52n^{17} - 224n^{16} - 381n^{15} + \dots}{8n^{18,5} + 48n^{17,5} + 136n^{16,5} + 914n^{15,5} + \dots} i, \\ R_4 &= \frac{4n^{20,5} + 20n^{19,5} + 25n^{19} + 61n^{18,5} + \dots}{4n^{20,5} + 24n^{19,5} + 68n^{18,5} + \dots} + \frac{8n^{18} - 52n^{17} - 224n^{16} - 381n^{15} + \dots}{8n^{18,5} + 48n^{17,5} + 136n^{16,5} + 914n^{15,5} + \dots} i. \end{aligned}$$

All corners lie in the first quadrant³ for $n > 10$. An approximation for $\varrho^{(4)}$ is therefore

$$|R_3| < \left| \varrho^{(4)} \right| < |R_2|.$$

For $n > 174$ we get the approximation

$$|R_2| = \left(\left(\frac{n^{20,5} + 5n^{19,5} + \dots}{n^{20,5} + 6n^{19,5} + \dots} \right)^2 + \left(\frac{n^{18} + 6n^{17} + 47n^{16} + \dots}{n^{18,5} + 6n^{17,5} + 17n^{16,5} + \dots} \right)^2 \right)^{(1/2)} < \sqrt{1 - \frac{1}{n^2}}$$

and for $n > 49$ the approximation

$$|R_3| = \left(\left(\frac{n^{20,5} + 5n^{19,5} - \dots}{n^{20,5} + 6n^{19,5} + \dots} \right)^2 + \left(\frac{2n^{18} - 13n^{17} - \dots}{2n^{18,5} + 12n^{17,5} + \dots} \right)^2 \right)^{(1/2)} > \sqrt{1 - \frac{3}{n}}.$$

Hence the assertion for $\rho^{(4)}$ follows.

(vi) The translated number $\rho^{(4)} - 1$:

³Exactly: $\Re(R_3) > 0$ for $n > 4$ and $\Im(R_3) > 0$ for $n > 10$.

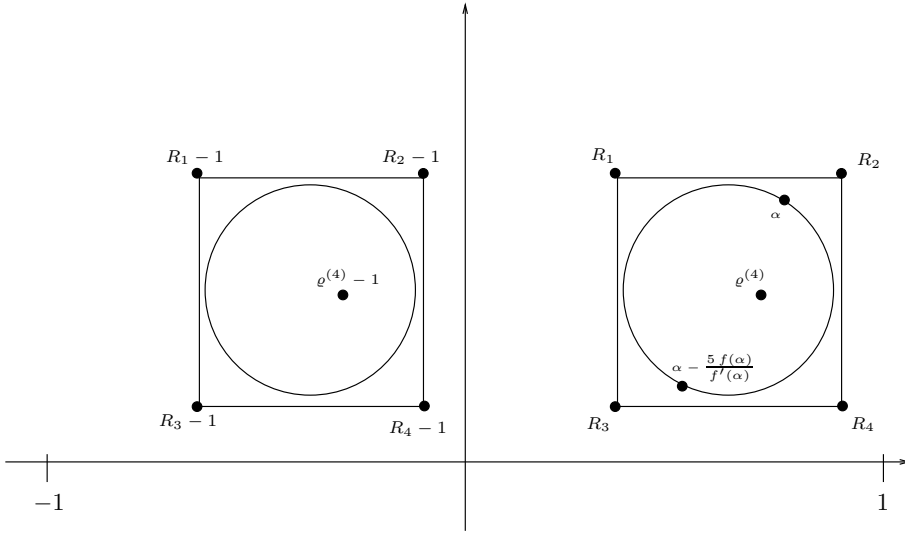

FIGURE 3. Approximation of $\varrho^{(4)}$ and $\varrho^{(4)} - 1$

For the approximation of $\varrho^{(4)} - 1$ the observation $\Re(R_i) < 1$ for $1 \leq i \leq 4$ is helpful: this is why all corners $R_1 - 1, \dots, R_4 - 1$ lie in the second quadrant (see figure 3) and we have

$$|R_1 - 1| > |\varrho^{(4)} - 1| > |R_4 - 1|.$$

We get the inequality

$$|R_1 - 1| = \left(\left(\frac{n^{20,5} + 5n^{19,5} - \dots}{n^{20,5} + 6n^{19,5} + \dots} - 1 \right)^2 + \left(\frac{n^{18} + 6n^{17} + 47n^{16} \dots}{n^{18,5} + 6n^{17,5} + 17n^{16,5} \dots} \right)^2 \right)^{1/2} < \sqrt{\frac{14}{13n}}$$

for $n > 54$, and the inequality

$$|R_4 - 1| = \left(\left(\frac{n^{20,5} + 5n^{19,5} + \dots}{n^{20,5} + 6n^{19,5} + \dots} - 1 \right)^2 + \left(\frac{2n^{18} - 13n^{17} - \dots}{2n^{18,5} + 12n^{17,5} + \dots} \right)^2 \right)^{1/2} > \sqrt{\frac{5}{6n}}$$

for $n > 139$. Hence the assertion for $\rho^{(4)}$ follows.

(vii) Position of $\varrho^{(2)}$ and $\varrho^{(4)}$:

Finally we have to show that $\varrho^{(2)}$ and $\varrho^{(4)}$ (and therewith $\rho^{(2)}$ and $\rho^{(4)}$) are different. This is because of the position of the roots (the first one close to 0 and the second one close to 1) or rather of the position of the enclosing squares.

Consider first the square belonging to the number $\alpha = \frac{1}{2n^2} + \frac{i}{\sqrt{n}}$: The real part of the right upper corner E_2 is (more exactly than before)

$$\Re(E_2) = \frac{5n^{19} + 2n^{18,5} + 20n^{18} - 5n^{17,5} + 10n^{17} - \frac{1}{2}n^{16,5} + 15n^{16} + 5n^{15,5} + \dots + \frac{25}{1024}\sqrt{n}}{4n^{2,5}(n+1)(n^{17} + 4n^{16} + 2n^{15} + 3n^{14} + n^{13} + \frac{19}{4}n^{12} + 7n^{11} + \dots + \frac{25}{1024})}.$$

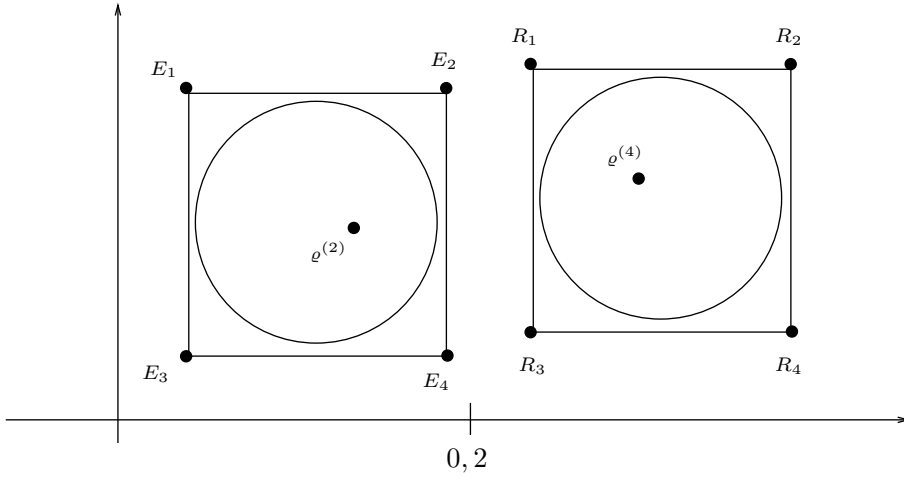

FIGURE 4. Position of the roots $\rho^{(2)}$ and $\rho^{(4)}$ in the first quadrant

For the second square belonging to the number $\alpha = 1 - \frac{1}{n} + \frac{3}{n^2} + \frac{i}{\sqrt{n}}$ the real part of the left upper corner R_1 is (more exactly than before)

$$\Re(R_1) = \frac{(4n^{19} + 20n^{18} - 25n^{17.5} + 61n^{17} - 150n^{16.5} + \frac{427}{2}n^{16} + \dots + \frac{492075}{2})}{n^2(4n^{17} + 24n^{16} + 68n^{15} + 457n^{14} - 496n^{13} + 6296n^{12} + \dots - 437400n + 164025)}.$$

For these real parts we have $\Re(E_2) < \frac{1}{5} < \Re(R_1)$ for all $n > 4$. Hence we have the situation as shown in figure 4.⁴ This implies that both squares are disjoint and that the roots $\rho^{(2)}$ and $\rho^{(4)}$ differ. So Lemma 4.4 is proven. \square

With these approximations we know the position of the five roots of $P_n(x)$ for $n \geq 7$ (see Lemma 4.2) and for $n \leq -175$ (see Lemma 4.4) sufficiently to prove Theorem 4.1.

Proof of Theorem 4.1. First we consider $n \geq 7$. To show the independence of the units ρ and $\rho - 1$ we assume their dependance in the form $\rho^k = \pm(\rho - 1)^l$ with $k, l \in \mathbb{Z}$. If this equality holds then it holds for all conjugates too in particular for $\rho^{(1)}$ and $\rho^{(3)}$. With the approximations in Lemma 4.2 we have $|\rho^{(1)}| < 1 < |\rho^{(1)} - 1|$ and $|\rho^{(3)} - 1| < \frac{2}{5} < \frac{3}{5} < |\rho^{(3)}| < 1$. Let $k > 0$. The inequality for the first conjugate implies $l > 0$ while the inequality for the third conjugate implies $l < 0$. Hence there is no l with $\rho^k = \pm(\rho - 1)^l$.

Analogue considerations yield a contradiction for $k < 0$. Hence the units ρ and $\rho - 1$ are independent for $n \geq 7$.

Now we consider $n \leq -175$. In this case by theorem 2.1 there are one real and two pair of complex roots. Suppose $\rho^k = \pm(\rho - 1)^l$ with $k, l \in \mathbb{Z}$. By Lemma 4.4 we have $0 < |\rho^{(2)}| < 1 < |\rho^{(2)} - 1| < 2$ and

⁴Both imaginary parts tend to 0 for $n \rightarrow \infty$ whereas $\Im(R_1) > \Im(E_2)$ holds for all $n > 0$.

$0 < |\rho^{(4)} - 1| < |\rho^{(4)}| < 1$; for $k > 0$ this implies $l < 0$ for the second conjugates and $l > 0$ for the fourth conjugates. For $k < 0$ an analogue argumentation yields a contradiction too.

To prove the fundamentality of these units in the equation order $\mathbb{Z}[\rho]$ we compute an upper and a lower approximation of the regulator. Since field extension $\mathbb{Q}(\rho)/\mathbb{Q}$ generated by $P_n(x)$ has no intermediate fields and since $|\text{disc}(\mathbb{Z}[\rho])| = 16(4n^3 - 28n^2 + 24n - 47)^2 > 5^5$ for $n \leq -175$ we use the lower regulator bound given by Pohst/Zassenhaus ([15], 5.6.22)

$$\text{Reg}(\mathbb{Z}[\rho]) \geq \sqrt{\frac{3}{5}} \frac{\left(\log\left(\frac{(4n^3 - 28n^2 + 24n - 47)^2}{5^5}\right)\right)^2}{36}.$$

For $n \leq -175$ and $\sqrt{5^5} < 56$ estimations of this bound yield

$$\begin{aligned} \text{Reg}(\mathbb{Z}[\rho]) &\geq \sqrt{\frac{3}{5}} \frac{1}{36} \left(\log\left(\left(\frac{4n^3}{\sqrt{5^5}}\right)^2\right)\right)^2 \\ &= \sqrt{\frac{3}{5}} \frac{1}{9} \left(\log\left(\frac{-4n^3}{\sqrt{5^5}}\right)\right)^2 \\ &\geq \frac{1}{3\sqrt{15}} (3 \log(-n) - \log(14))^2 =: R_u. \end{aligned}$$

An upper regulator bound is computed with the help of the approximations of $\rho^{(1)}$ and $\rho^{(4)}$ given in lemma 4.4:

$$\begin{aligned} \text{Reg}(\mathbb{Z}[\rho]) &= \left| \det \begin{pmatrix} \log |\rho^{(1)}| & 2 \log |\rho^{(4)}| \\ \log |\rho^{(1)} - 1| & 2 \log |\rho^{(4)} - 1| \end{pmatrix} \right| \\ &= -2 \left(\log |\rho^{(1)}| \log |\rho^{(4)} - 1| - \log |\rho^{(1)} - 1| \log |\rho^{(4)}| \right) \\ &\leq 2 \left(\log(-n + 2 + \frac{1}{n}) \cdot \left(-\log\left(\left(\frac{-5}{6n}\right)^{(1/2)}\right)\right) \right). \end{aligned}$$

The last inequality follows from $|\rho^{(1)} - 1| > 1$ and $|\rho^{(4)}| < 1$. Therefore we get the upper regulator bound

$$\text{Reg}(\mathbb{Z}[\rho]) \leq \left(\log(-n) + \log\left(1 - \frac{2}{n} - \frac{1}{n^2}\right)\right) \cdot \left(\log(-n) + \log\left(\frac{6}{5}\right)\right),$$

which is simplified with $n \leq -175$ to

$$\leq \left(\log(-n) + \log\left(1 + \frac{2}{175}\right)\right) \cdot \left(\log(-n) + \log\left(\frac{6}{5}\right)\right) =: R_o.$$

The quotient $\frac{R_o}{R_u}$ of upper and lower regulator bound is smaller than 2 for $n < -130$. Hence $\{\rho, \rho - 1\}$ is a set of fundamental units of $\mathbb{Z}[\rho]$ for all $n \leq -175$.

The independency and the fundamentality of the units ρ and $\rho - 1$ in the equation order $\mathbb{Z}[\rho]$ for $-174 \leq n < 6$ are shown by calculations with KANT [5]. \square

Acknowledgment: We would like to thank the referee for insightful comments and suggestions.

References

- [1] H. COHEN, *A Course in Computational Algebraic Number Theory*. (Graduate Texts in Mathematics **138**), Springer, 1993.
- [2] G. DEGERT, *Über die Bestimmung der Grundeinheit gewisser reell-quadratischer Zahlkörper*. Abh. Math. Sem. Univ. Hamburg **22** (1958), 92–97.
- [3] G. FREI, *Fundamental systems of units in number fields $Q(\sqrt{D^2+d}, \sqrt{D^2+4d})$ with $d \mid D$* . Arch. Math. (Basel) **36.2** (1981), 137–144.
- [4] K. GEISSLER, *Berechnung von Galoisgruppen über Zahl- und Funktionenkörpern*. Thesis TU Berlin (2003).
- [5] KANT: <http://www.math.tu-berlin.de/~kant>
- [6] S. KATAYAMA, *The abc conjecture, fundamental units and the simultaneous Pell equations*. Proc. Jangjeon Math. Soc. **1** (2000), 19–26.
- [7] O. KIHEL, *Groupe des unités pour des extensions diédrales complexes de degré 10 sur \mathbb{Q}* . J. Théor. Nombres Bordx. **13.2** (2001), 469–482.
- [8] Y. KISHI, *A family of cyclic cubic polynomials whose roots are systems of fundamental units*. J. Number Theory **102.1** (2003), 90–106.
- [9] F. LEPRÉVOST, M.E. POHST, A.M. SCHÖPP, *Familles de polynômes liées aux courbes modulaires $X_0(l)$ unicursales et points rationnels non-triviaux de courbes elliptiques quotient*. Acta Arith. **110.4** (2003), 401–410.
- [10] F. LEPRÉVOST, M.E. POHST, A.M. SCHÖPP, *Units in some parametric families of quartic fields*. To appear in Acta Arithm. (2007).
- [11] MAGMA: <http://magma.maths.usyd.edu.au>
- [12] E. MAUS, *Zur Arithmetik einiger Serien nichtauflösbarer Gleichungen 5. Grades*. Abh. Math. Semin. Univ. Hamb. **54** (1984), 227–250.
- [13] K. NAKAMULA, *Certain Quartic Fields with Small Regulators* J. Number Theory **57** (1996), 1–21.
- [14] N. OBRESCHKOFF, *Verteilung und Berechnung der Nullstellen reeller Polynome*. (Hochschulbücher für Mathematik **55**), Dt. Verlag der Wissenschaften, 1963.
- [15] M.E. POHST, H.J. ZASSENHAUS, *Algorithmic algebraic number theory*, (Encyclopedia of Mathematics and its applications), Cambridge University Press, 1997.
- [16] A.M. SCHÖPP, *Über Torsionspunkte elliptischer und hyperelliptischer Kurven nebst Anwendungen*. Thesis TU Berlin (2005).
- [17] R. SCHOOF, L.C. WASHINGTON, *Quintic polynomials and real cyclotomic fields with large class numbers*. Math. Comput. **50.182** (1988), 543–556.
- [18] Y.-Y. SHEN, *Unit groups and class numbers of real cyclic octic fields*. Trans. Am. Math. Soc. **326.1** (1991), 179–209.
- [19] H.-J. STENDER, *Einheiten für eine allgemeine Klasse total reeller algebraischer Zahlkörper*. J. Reine Angew. Math. **257** (1972), 151–178.
- [20] H.-J. STENDER, *Grundeinheiten für einige unendliche Klassen reiner biquadratischer Zahlkörper mit einer Anwendung auf die diophantische Gleichung $x^4 - ay^4 = \pm c$ ($c = 1, 2, 4$ oder 8)*. J. Reine Angew. Math. **264** (1973), 207–220.
- [21] H.-J. STENDER, *Eine Formel für Grundeinheiten in reinen algebraischen Zahlkörpern dritten, vierten und sechsten Grades*. J. Number Theory **7** (1975), 235–250.
- [22] H.-J. STENDER, *„Verstümmelte“ Grundeinheiten für biquadratische und bikubische Zahlkörper*. Math. Ann. **232.1** (1978), 55–64.

- [23] E. THOMAS, *Fundamental units for orders in certain cubic number fields*. J. Reine Angew. Math. **310** (1979), 33–55.
- [24] K. WANG, X. ZHANG, *Fundamental unit system and class number for real number field of type $(2,2,2)$* . Tsinghua Sci. Technol. **5.2** (2000), 150–153.
- [25] K. WANG, *Fundamental unit systems and class number of real bicyclic biquadratic number fields*. Proc. Japan Acad. Ser. A Math. Sci. **77.9** (2001), 147–150.

Andreas M. SCHÖPP
Technische Universität Berlin
Straße des 17. Juni 136,
10623 Berlin, Germany
E-mail: schoepp@math.tu-berlin.de